



Helitune

Engineering Rotortuner Solutions

H904 Accelerometer

High Frequency IEPE Shear Accelerometer

Designed by Aircraft Engineers for Aircraft Engineers

Description

The H904 Accelerometer has been custom engineered for the collection of rotor balance & vibration data in the range of 1Hz to 10kHz. Its small size and weight make it the perfect accompaniment to Helitune's portable systems; however, it is also suitable for permanent installation.

Constructed from a corrosion-resistant stainless steel, it provides a hermetically-sealed solution that offers continuous performance at operating temperatures of up to 150°C.

- High Frequency Performance
- Excellent Linearity
- Electrically Isolated
- Safety Locking Wire Holes

Note: Accelerometers should always be correctly mounted using purpose-designed mounting solutions. Failure to do this could result in inconsistencies with measured values.



Actual Size

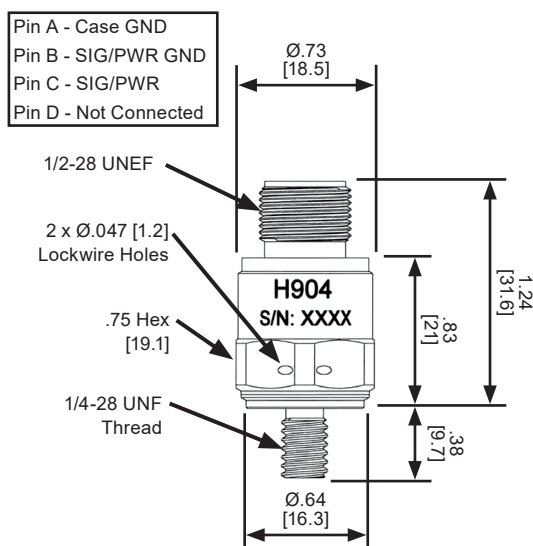

Typical Frequency Response

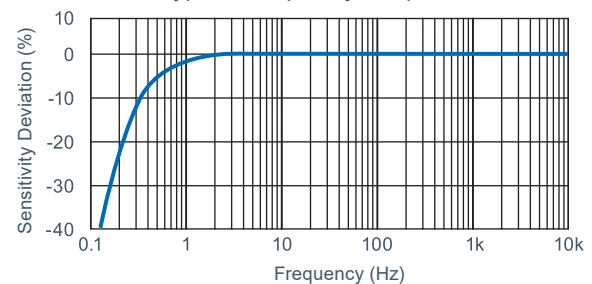

Typical Temperature Response

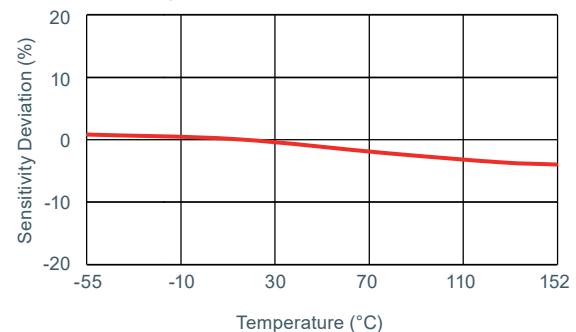

Performance

Sensitivity, $\pm 5\%$, [1]	25 mV/g
Acceleration Range	$\pm 200g$ peak (F.S. for ± 5 Volts Output)
Amplitude Non-Linearity	$\pm 1\%$
Frequency Response:	$\pm 5\%$0.5 - 10,000 Hz $\pm 15\%$0.25 - 15,000 Hz
Resonance Frequency	>30 kHz
Transverse Sensitivity MAX	$\pm 5\%$
Temperature Response	See graph
Strain Sensitivity	0.002 g/ μ strain

Electrical

Supply Current Range [2]	2-20mA
Compliance Voltage	+18V to +30V DC
Output Impedance, Typ	100 Ω
Bias Output Voltage	+7.5V to +9.5V DC
Electrical Isolation	(Pin B & C) to case 10 G Ω , min

Environmental

Temperature Range	-55°C to 150°C
Vibration MAX	$\pm 600g$ peak
Shock MAX	$\pm 3,000g$ peak
Sealing	Hermetic

Physical

Weight	45 grams (MAX)
Case Material	Stainless steel
Mounting	1/4-28 UNF stud
Output Connector	Threaded 4 pin plug (Custom)
Mating Connector	Threaded 4 pin socket (Custom)

[1] Measure at 80Hz @ 1g pk

[2] Do not apply power to this system without current limiting, 20 mA MAX. To do so will damage the IC charge amplifier.

To ensure the correct operation of accelerometers with Helitune equipment, it is necessary for annual calibration to be carried out by Helitune Authorised Test Centres.



Helitune's Quality Management System is certified to BS EN ISO9001 and AS9100

This document is not contractual. Helitune maintain a policy of continuous product development and improvement. This specification may change without notice.

PB-3698-02 Issue 1 / Nov 2018
A4

Helitune UK
Hatchmoor Industrial Estate, Torrington
Devon EX38 7HP, UK

Phone +44(0)1805 624650, Fax +44(0)1805 624 689
Registered in England & Wales, No. 3979088
VAT Reg. No. 762 442 630

Helitune Germany
Lilienthalstraße 2a
82205 Gilching, Germany

Helitune USA
190 Gordon Street
Elk Grove Village, IL 60007-1120, USA

Helitune Italy
Via Ferrarese, 3
40128 Bologna, Italy

www.helitune.com